



# H15 SX

## Exceptional rough terrain capability

- Hydraulic differential lock for improved RT capability
- 35cm ground clearance ensures exceptional rough terrain performance
- 4 wheel drive

## Excellent manoeuvrability

- Tight turning radius
- Proportional controls for extremely smooth movements



**Haulotte**   
GROUP  
More than lifting





# H15 SX

## ROUGH TERRAIN SCISSOR LIFTS

### TECHNICAL DATA

### H15 SX

|                                   |                 |
|-----------------------------------|-----------------|
| Working height                    | 15 m            |
| Platform height                   | 13 m            |
| Drive speed                       | 1.6 - 6 km/h    |
| Driveable at full height up to    | 10 m            |
| Lift capacity                     | 500 kg          |
| <b>H</b> Length                   | 4.12 m          |
| <b>B</b> Width                    | 2.25 m          |
| <b>C</b> Height - stowed          | 2.77 m          |
| Storage height                    | 1.91 m          |
| <b>G</b> Platform length          | 4 m             |
| <b>A</b> Extended platform length | 6 m             |
| Platform extension length         | 1 m             |
| <b>F</b> Platform width           | 1.89 m          |
| <b>D</b> Wheelbase                | 2.75 m          |
| <b>E</b> Ground clearance         | 35 cm           |
| Number of extensions              | 2               |
| Turning radius - outside          | 4.96 m          |
| Lift / lower speed                | 46 s / 57 s     |
| Engine                            | 23.1 kW - 31 Hp |
| Gradeability                      | 40 %            |
| Tires - foam-filled               | 10-16.5         |
| Hydraulic system capacity         | 100 l           |
| Weight                            | 6340 kg         |

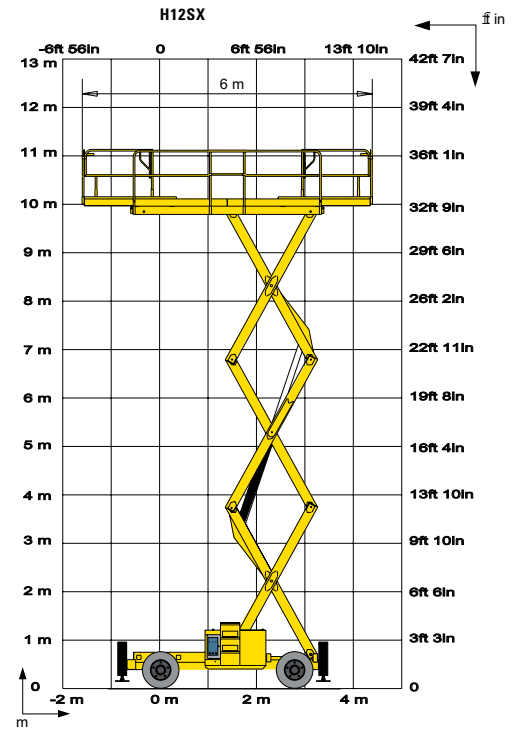

### STANDARD EQUIPMENT

- 4 wheel drive (2 wheel steer)
- 5° tilt alarm
- 2 metres of platform extension
- Platform Load Management System
- 12 V - 95 Ah batteries
- 14 V - 50 A alternator
- Removable operator's control box
- Free wheeling device
- Hourmeter
- Horn
- Towing and lifting hooks
- Hydraulic brakes
- Centralised stabiliser (H18 SX)
- Manual emergency lowering system

### OPTIONS AND ACCESSORIES

- Rotating beacon
- Travel alarm
- Power to platform
- Working light
- Encoded starting device
- Biodegradable hydraulic oil
- Motion alarm for movements and translation
- Non-marking tyres
- Warm Environment Kit
- Centralised outrigger control with automatic levelling (standard on H18SX)

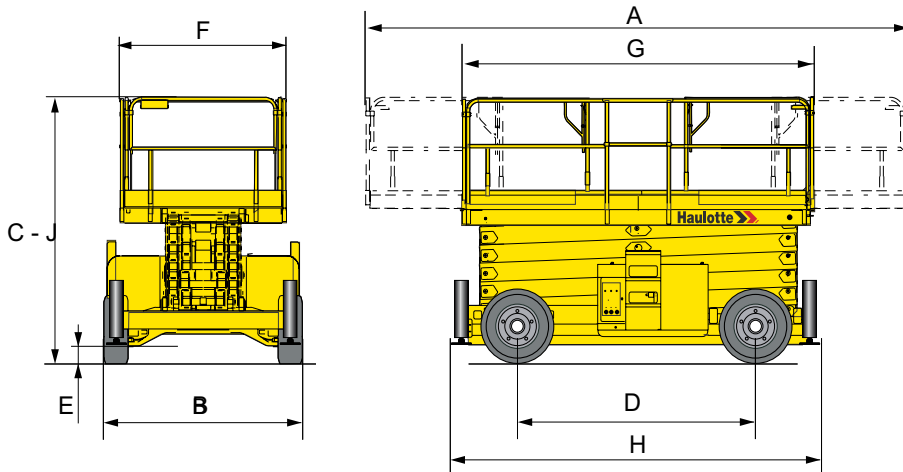

Authorised Reseller : Shakti Equipments Pvt. Ltd.

Block No. 140, Near Vitawa Octroi Naka, Thane Belapur Road, Vitawa, Thane West - 400 605.

Tel: +91 - 22 - 2542 0127 Email: info@shaktiequipments.com