



H18 SX

Exceptional rough terrain capability

- Hydraulic differential lock for improved RT capability
- 35cm ground clearance ensures exceptional rough terrain performance
- 4 wheel drive

Excellent manoeuvrability

- Tight turning radius
- Proportional controls for extremely smooth movements





H18 SX

ROUGH TERRAIN SCISSOR LIFTS

TECHNICAL DATA

H18 SX

Working height	18 m
Platform height	16 m
Drive speed	1.6 - 6 km/h
Driveable at full height up to	10 m
Lift capacity	500 kg
H Length	4.18 m
B Width	2.25 m
C Height - stowed	2.97 m
Storage height	2.11 m
G Platform length	4 m
A Extended platform length	6 m
Platform extension length	1 m
F Platform width	1.89 m
D Wheelbase	2.75 m
E Ground clearance	35 cm
Number of extensions	2
Turning radius - outside	4.96 m
Lift / lower speed	60 s / 60 s
Engine	23.1 kW - 31 Hp
Gradeability	40 %
Tires - foam-filled	10-16.5
Hydraulic system capacity	100 l
Weight	7300 kg

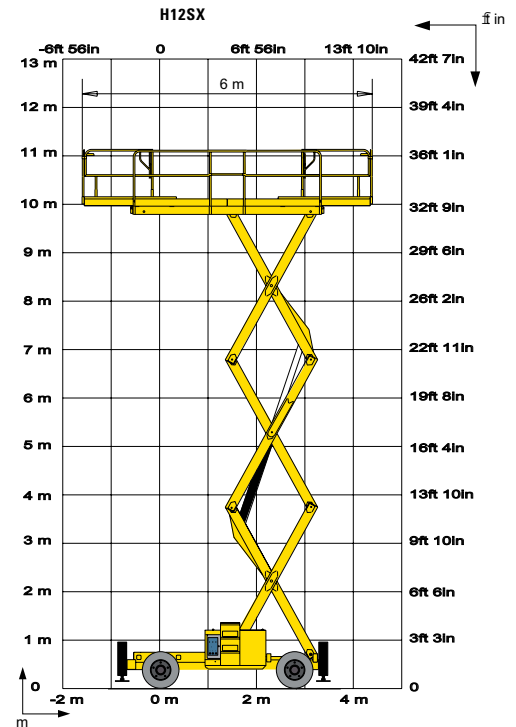

STANDARD EQUIPMENT

- 4 wheel drive (2 wheel steer)
- 5° tilt alarm
- 2 metres of platform extension
- Platform Load Management System
- 12 V - 95 Ah batteries
- 14 V - 50 A alternator
- Removable operator's control box
- Free wheeling device
- Hourmeter
- Horn
- Towing and lifting hooks
- Hydraulic brakes
- Centralised stabiliser (H18 SX)
- Manual emergency lowering system

OPTIONS AND ACCESSORIES

- Rotating beacon
- Travel alarm
- Power to platform
- Working light
- Encoded starting device
- Biodegradable hydraulic oil
- Motion alarm for movements and translation
- Non-marking tyres
- Warm Environment Kit
- Centralised outrigger control with automatic levelling (standard on H18SX)

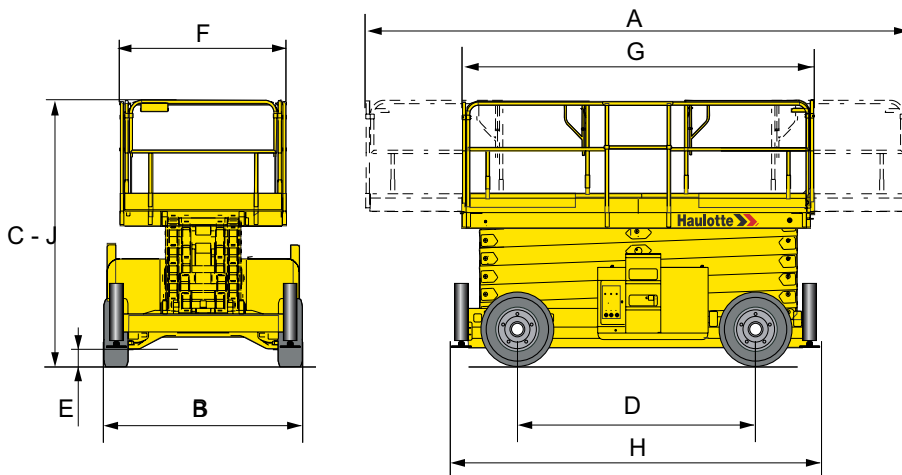

Authorised Reseller : Shakti Equipments Pvt. Ltd.

Block No. 140, Near Vitawa Octroi Naka, Thane Belapur Road, Vitawa, Thane West - 400 605.

Tel: +91 - 22 - 2542 0127 Email: info@shaktiequipments.com